

## ***DIRECTIONS***

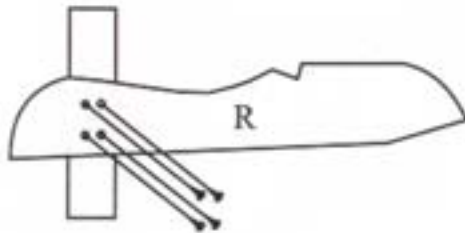

1. Attach legs (#1) to sides (#9) using 4 plated screws. Sides are marked left and right and have pre-drilled holes, the remaining side is actually a middle.

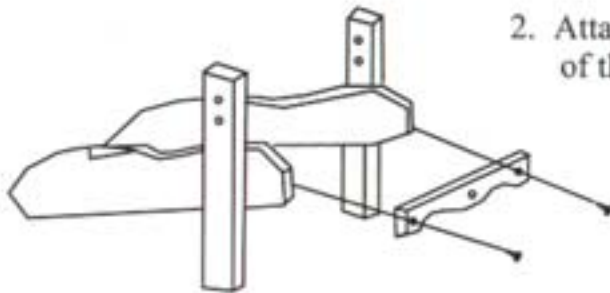

2. Attach front slat (#8) to the front bottom edge of the sides using 2 screws.

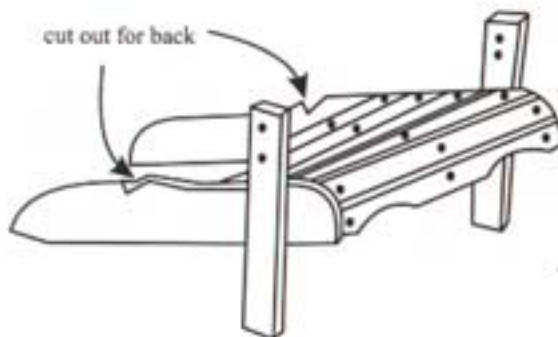

3. Attach the 6 seat slats (#6) to the sides. Evenly space the slats along the sides (approx. 1/4" spacing) To ensure the sides stay parallel while attaching the slats temporarily attach a slat in the "cutout for the back." Attach the comfort slat (#7) on the angled edge in front of the "cutout for back" with 2 screws. Attach the remaining side (middle) to the centre of the seat slats, starting at the front slat, aligning the side with the pre-drilled holes in the seat slats and screw in.